

# Café™ 36" Built-In Touch Control Induction Cooktop

CHP95362MSS

\$2299 MSRP

CAFÉ

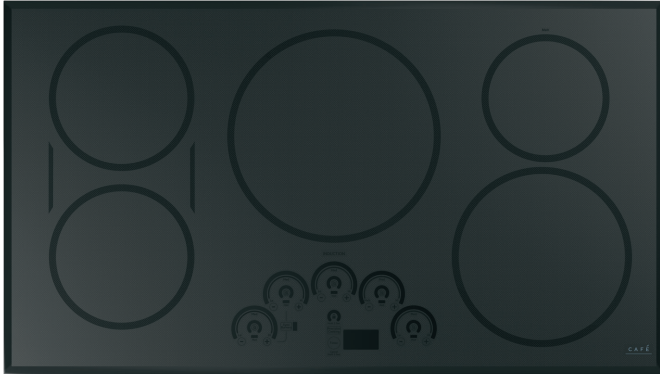

## FEATURES & BENEFITS

Control your cooktop from any room in the house with your Smart phone using **Wifi Connect**.

Prep like a pro with rapid, precise heat control that stays cool to the touch using **five induction elements**.

When you're updating your kitchen, attention to detail is a priority. That's why Café cooktops are guaranteed for an exact fit for an easy and seamless replacement.

Make your cooking process as impressive as the food itself, with **touch controls** that let you control heat with just one swipe.

Cook pastas al dente in no time, with an **11" induction element** that boils water in 101 seconds.

Evenly heat large cookware like griddles or dutch ovens by controlling **two 7" synchronized elements** with just the touch of a button.

Make multitasking look easy with a **multi-element timer** that lets you manage up to five pans at once.

Prevent unintended burner activation with **control lock capability**.

Customize your cooktop to meet your unique needs with **personalized settings**.

Sear with speed with **Pan presence and size sensors** that heat to the size of your pan and turn off when it's off the cooktop.

## APPEARANCE

Color Appearance	Stainless Steel
Frameless	Yes

## FEATURES

Cooktop Surface	Gray Ceramic Glass with Beveled-Edge
Cooktop Burner Type	5 Induction Elements
Element - Left Front	7" 2500W
Element - Left Rear	7" 2500W
Element - Right Front	8" 3200W
Element - Right Rear	6" 1800W
Element - Center	11" 3700W
Control Location	Front Center
Control Type	Glide Touch
Element - Right Rear	6" 1800W
Control Location	Front Center
Control Type	Glide Touch
Cooktop Control Features	All-Off Control Control Lock Capability Custom Settings Kitchen timer Melt Setting Multi-element timer Sync-Burners Capability
Melt Setting	Yes
Indicator Lights	5 Hot Surface Surface Element "ON" Setting Level Indicators Blue/Red
Power Cord Length	36"
Timer	Yes
Optional Accessories	JXSOU5V1 - Precision cooking probe

## WEIGHTS & DIMENSIONS

Approximate Shipping Weight	57 lb
Cabinet Width	36 in
Cooktop Size	36 in
Cutout Dimensions (Width x Depth) (In.)	33-7/8 x 19-1/8
Net Weight	50 lb
Overall Depth	20 3/8 in
Overall Height	4 5/8 in
Overall Width	36 in

## POWER/RATINGS

Amp Rating at 208V	50
Amp Rating at 240V	50
KW Rating at 208V	9.6
KW Rating at 240V	11.1

## ACCESSORIES

Griddle	Included
---------	----------

# Café™ 36" Built-In Touch Control Induction Cooktop



CHP95362MSS

## WARRANTY

Parts warranty	Limited 1-year entire appliance
Labor warranty	Limited 1-year entire appliance

## DIMENSIONS AND INSTALLATION

**Important:** Requires a 3" free area between the bottom of the cooktop to any combustible material, i.e., shelving. Free area not required when installing wall oven underneath cooktop. Refer to installation instructions. Requires a 15" minimum from cooktop to adjacent overhead cabinets. Units are furnished with a 48" flexible armored cable.

**Note:** 36" induction cooktops are approved for use over select GE 30" Single Wall Ovens and Warming Drawers. Refer to cooktop and wall oven/warming drawer installation instructions packed with product for current dimensional data. If installed with a GE Telescopic Downdraft System, consult both the cooktop and downdraft installation instructions packed with product before installing. Cooktop gas/electric supply may need to be re-routed to install downdraft. The countertop cutout requires 23-1/2" minimum flat countertop surface and 25" minimum total countertop depth. In addition, other clearances to front edge of the countertop must be considered.

**Before installing, consult installation instructions packed with product for current dimensional data.**

### KW RATING

240V	11.1
208V	9.6

### AMPERAGE

240V	50 Amps†
208V	50 Amps†

**Note:** Check local codes for required breaker size.

### Installation above a wall oven

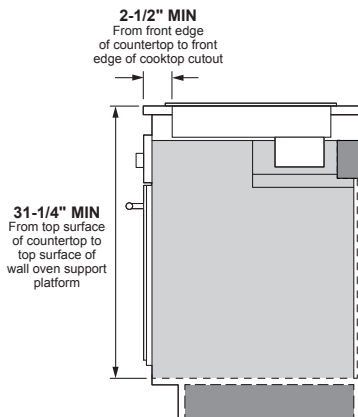

### Approximate Cooking Dimensions

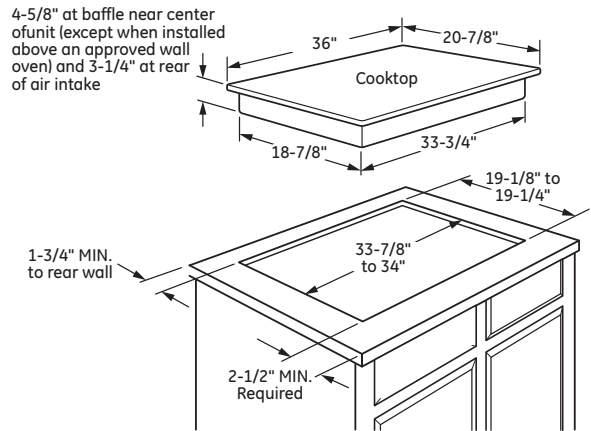

To insure accuracy, it is best to make a template when cutting the opening in the counter

